

CCA9100 – Dual CAN Bus Transceiver

DUAL CAN BUS TRANSCEIVER

FEATURES

- ISO 11898 compatible
- two independent CAN transceiver in one package or die
- CAN-H, -L bus lines protected against short circuit and transients in automotive applications
- Differential receiver with wide common-mode range for high immunity against EMI
- Slope control
- Wide operating temperature range -40 to 125 °C
- Thermal protection with monitoring output
- Low power standby mode
- Digital supply range 3.3 to 5V
- Single supply operation possible
- Low cost

BLOCK DIAGRAM

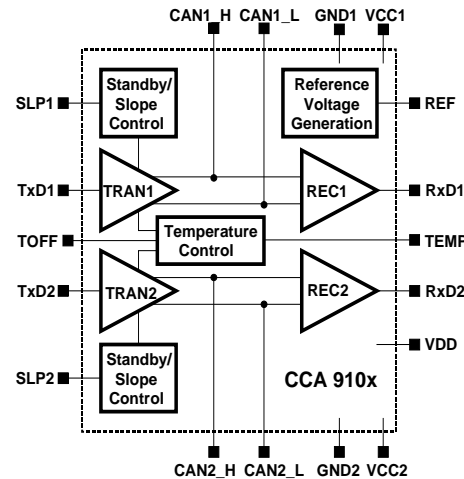

PIN CONFIGURATION

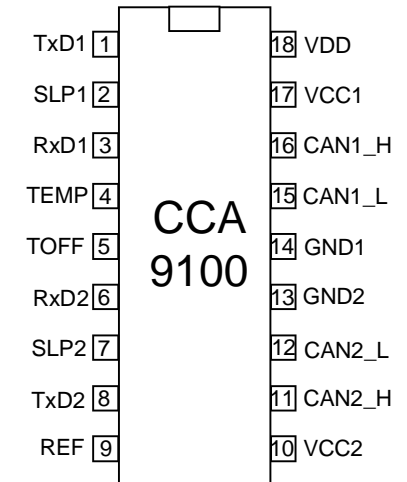

GENERAL DESCRIPTION

The CCA9100 dual 'Control Area Network' transceiver offers two individual interfaces between the CAN controllers and the physical bus lines. Both transceivers provide differential drive and receive capability between the bus and the CAN controllers. Because of its wide temperature range (-40 to 125 °C) and the protected bus pins the CCA9100 is best suited for automotive and industrial applications.

ABSOLUTE MAXIMUM RATINGS:

Parameter	Symbol	Conditions	Min.	Max.	Unit
Supply voltages	V_{CC}, V_{DD}		-0.3	+18	V
Voltage on any pin except CANx_H,L			-0.3	$V_{CC}+0.3$	V
Voltage on bus pins	V_{CAN1-H}, V_{CAN1-L} V_{CAN2-H}, V_{CAN2-L}		-18	+18	V
Max. transmission speed	$1/t_{CAN}$	$V_{SLP1}, V_{SLP2} < 0.3 * V_{CC}$	250		kbaud
Continuous output current			-150	+150	mA
Operating temperature	T_{OP}		-40	+125	°C

Disclaimers:
Creative Chips GmbH reserves the right to make changes without further notice to any products herein to improve reliability, function or design. Creative Chips does not assume any liability arising out of the application or use of any product or circuit described herein; neither does it convey any license under its patent rights, nor the rights of others. These products are not authorized for use as critical components in life support devices or systems without the express written approval of Creative Chips.

